



Silo features: 65M3

Size	35 50 65 80 95 110 125	65
Class	2 = Medium (ex S9)	
Version	1 = Standard 2 = Heavy	1
Legs	+ = Excluded 1 = Standard	1
Provision for filtration	+ = Excluded TSF = Exhaust pipe SIL = Silotop upstand UF6 = Upstand for 13m2 UF8 = Upstand for 20m2	SIL
Provision for PRV	+ = Excluded 1 = Upstand for VCP2731 2 = Upstand for VCP3751	1
Provision for IPM	+ = Excluded 1 = With	+
Provision for filling pipe	+ = Filling pipe excluded C = Filling pipe included 1 = Only spigot for filling pipe 168 2 = Only spigot for filling pipe 219 3 = Only spigot for filling pipe 273	C
Boss for ILT from the roof of the silo	+ = Excluded 1 = One boss 2 1/2'' 2 = One boss 1 1/2'' 3 = Both	1
Lower cone	+ = Excluded 56= Included at 56 degrees DB= Double spout, symmetrical 15= for Bin activator 150 18= for Bin activator 180	56
Provision for fluidisation	+ = Excluded F04 = 4 holes 14mm dia F08 = 8 holes 14mm dia V04 = 4 holes 23mm dia V08 = 8 holes 23mm dia M04 = 4 bosses 2'' with cap M08 = 8 bosses 2'' with cap	M08
Outlet flange	+ = Excluded 1 = Standard for butterfly valves V_FS 2 = XKF75.1 for VLC/VLQ)	1
Surface finishing	+ = None 3 = Std SA21/2 synthetic primer 80micron + enamel 40micron 5 = SA21/2 phosphate primer 80micron + enamel 40micron 7 = Hot galvanization	+
Surface treatment	0 = None if finishing is galvanization + = RAL Z = Special	RAL



Ladder	+ = Excluded	SCA35
	SCA35 = Included (Standard)	
	SCA351=Ladder with bottom cage	
	SCA352=Ladder with upper safety door	
Upper railing	SCA353=Ladder with cage and door	PAR351
	1 = Excluded	
	PAR351 = Included with one opening	
	PAR352 = Included with two openings	
Connecting gangway	+ = Excluded	+
	1 = Gangway for silo centre distance 3660mm	
	2 = Gangway for silo centre distance between & 4200mm	
	3 = Gangway for silo centre distance between 4200 & 4350mm	
Pipe ILT cable	4 = Gangway for silo centre distance between 4350 & 4500mm	+
	+ = Excluded	
	PCV35 = With pipe for ILT cable	
Legs support kit	+ = Excluded	+
	KPR35-0285 = 285mm extension	
	KPR35-0570 = 570mm extension	
	KPR35-0855 = 855mm extension	
Ladder extension	KPR35-1140 = 1140mm extension	+
	+ = Excluded	
	TPR35-0285 = 285mm extension	
	TPR35-0570 = 570mm extension	
Filling pipe / exhaust pipe extension	TPR35-0855 = 855mm extension	+
	TPR35-1140 = 1140mm extension	
	+ = Excluded	
	SPR35-0285 = 285mm extension	
Reduction kit (2" to 1")	SPR35-0570 = 570mm extension	+
	SPR35-0855 = 855mm extension	
	SPR35-1140 = 1140mm extension	
	+ = Excluded	
Packing	4 = 4 off	+
	8 = 8 off	
	T = for truck	
	C = for container	

Outer / inner dia 3,588mm / 3,468mm
Standards ENV 1991-1:1996 Eurocode 1-1 Calculations basis
(among others) ENV 1991-2-1:1996 Eurocode 1-2 Actions on structure
ENV 1991-2-3:1996 Eurocode 1-2-3 Snow loads
ENV1991-2-4:1997 Eurocode 1-2-4 Wind actions
ENV 1993-1-1-:1994A1:1998 Eurocode 3-1-1 Steel structures
UNI EN 131/1 1994 Step ladders, stairways
EN ISO 14122-3:2001 Stairways, stepladders, and guardrails
Construction In carbon steel S235JR (EN134)
Silo suitable for **Cement @ 1.4 density**
Drawing of the silo Attached.
Delivery 6-7 WEEKS DELIVERY



STALLINGS HOUSE • STALLINGS LANE • KINGSWINFORD • WEST MIDLANDS • DY6 7LG

A TRADING DIVISION OF MIDLAND SPECIALIST ENGINEERING

COMPANY REGISTRATION No. 5240743

VAT REGISTRATION No. 851 207 156



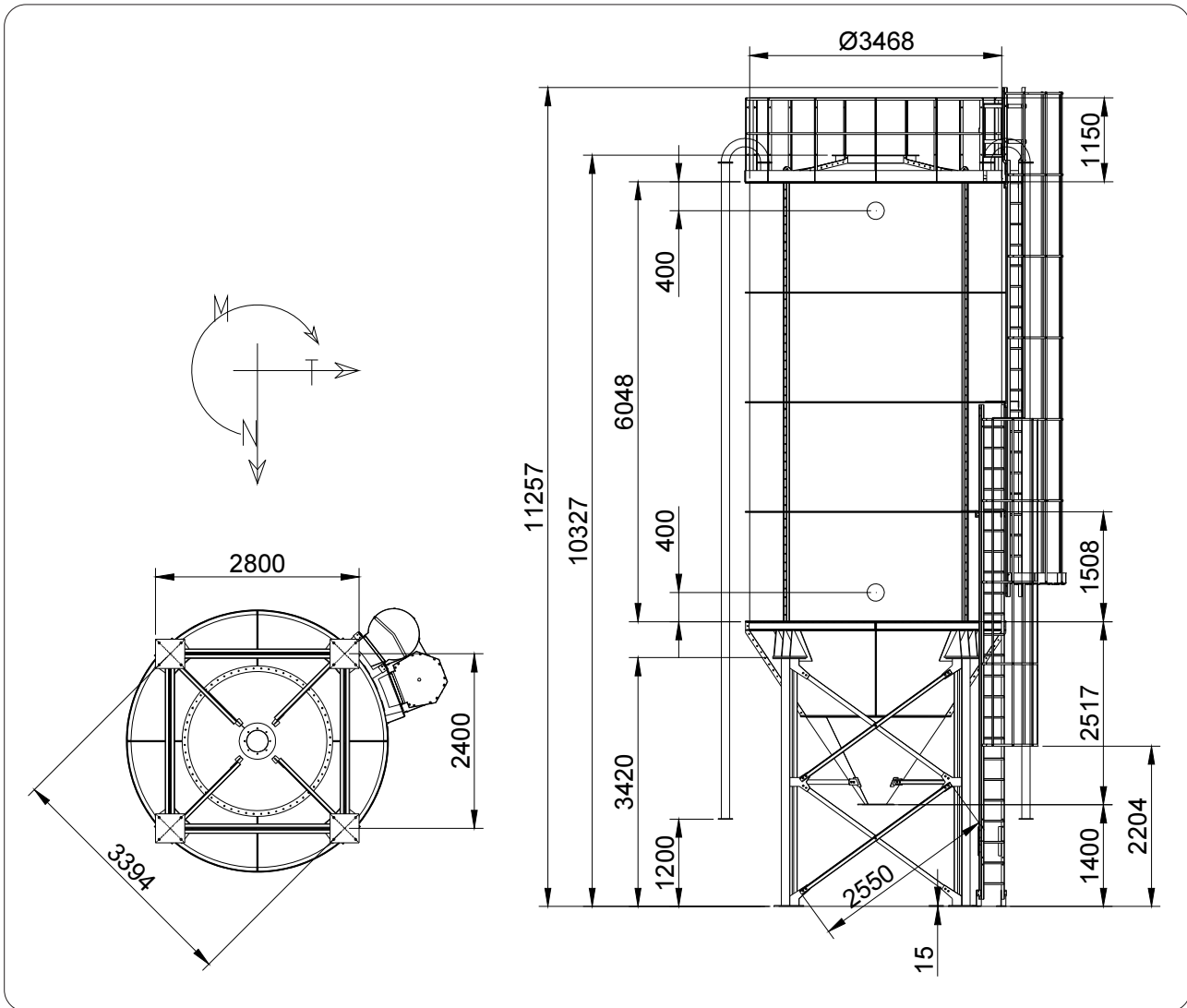

Max. stresses on individual columns - Max. Belastung der einzelnen Säulen
 Contraintes maximales de chaque colonne - Sollecitazioni massime singole colonne

Code	Ferrules Siloschüsse Viroles - Virole	Capacity Fassungsvermögen Capacité - Capacità		Full silo - Silo voll Silo plein - Silo pieno			Empty silo in presence of wind Leerer Silo bei Wind Silo déchargé en présence de vent Silo scarico in presenza di vento		
		N°	m³ (*)	T (**)	N	T	M	N	T
SPG35.065.04	4	65	91	34189 kgf	650 kgf	negligible vernachlässigbar	-1674 kgf	625 kgf	negligible vernachlässigbar
SPG35.065.02				45040 kgf	2425 kgf	négligeable trascurabile	-1520 kgf	625 kgf	négligeable trascurabile

04 = Area - Zone - Zone - Zona 4
 02 = Area - Zone - Zone - Zona 2

(*) Silo internal volume - Silovolumen - Volume intérieur silo - Volume interno silo

(**) Specific wt. of reference material (cement): 1.4 kg/dm³ - Spezifisches Gewicht des Bezugsmaterials (Zement): 1,4 kg/dm³
 Poids spécifique matériau de référence (ciment): 1,4 kg/dm³ - Peso specifico materiale di riferimento (cemento): 1,4 kg/dm³