



## Silo features: 110M3

<b>Size</b>	35 50 65 80 95 110 125	110
<b>Class</b>	2 = Medium (ex S9)	
<b>Version</b>	1 = Standard      2 = Heavy	1
<b>Legs</b>	+ = Excluded      1 = Standard	1
<b>Provision for filtration</b>	+ = Excluded TSF = Exhaust pipe SIL = Silotop upstand UF6 = Upstand for 13m2 UF8 = Upstand for 20m2	SIL
<b>Provision for PRV</b>	+ = Excluded 1 = Upstand for VCP2731 2 = Upstand for VCP3751	1
<b>Provision for IPM</b>	+ = Excluded 1 = With	+
<b>Provision for filling pipe</b>	+ = Filling pipe excluded C = Filling pipe included 1 = Only spigot for filling pipe 168 2 = Only spigot for filling pipe 219 3 = Only spigot for filling pipe 273	C
<b>Boss for ILT from the roof of the silo</b>	+ = Excluded 1 = One boss 2 1/2'' 2 = One boss 1 1/2'' 3 = Both	1
<b>Lower cone</b>	+ = Excluded 56= Included at 56 degrees DB= Double spout, symmetrical 15= for Bin activator 150 18= for Bin activator 180	56
<b>Provision for fluidisation</b>	+ = Excluded F04 = 4 holes 14mm dia F08 = 8 holes 14mm dia V04 = 4 holes 23mm dia V08 = 8 holes 23mm dia M04 = 4 bosses 2'' with cap M08 = 8 bosses 2'' with cap	M08
<b>Outlet flange</b>	+ = Excluded 1 = Standard for butterfly valves V_FS 2 = XKF75.1 for VLC/VLQ)	1
<b>Surface finishing</b>	+ = None 3 = Std SA21/2 synthetic primer 80micron + enamel 40micron 5 = SA21/2 phosphate primer 80micron + enamel 40micron 7 = Hot galvanization	+
<b>Surface treatment</b>	0 = None if finishing is galvanization + = RAL Z = Special	RAL

<b>Ladder</b>	+ = Excluded	SCA35
	SCA35 = Included (Standard)	
	SCA351=Ladder with bottom cage	
	SCA352=Ladder with upper safety door	
<b>Upper railing</b>	SCA353=Ladder with cage and door	PAR351
	1 = Excluded	
	PAR351 = Included with one opening	
	PAR352 = Included with two openings	
<b>Connecting gangway</b>	+ = Excluded	+
	1 = Gangway for silo centre distance 3660mm	
	2 = Gangway for silo centre distance between & 4200mm	
	3 = Gangway for silo centre distance between 4200 & 4350mm	
<b>Pipe ILT cable</b>	4 = Gangway for silo centre distance between 4350 & 4500mm	+
	+ = Excluded	
	PCV35 = With pipe for ILT cable	
<b>Legs support kit</b>	+ = Excluded	+
	KPR35-0285 = 285mm extension	
	KPR35-0570 = 570mm extension	
	KPR35-0855 = 855mm extension	
<b>Ladder extension</b>	KPR35-1140 = 1140mm extension	+
	+ = Excluded	
	TPR35-0285 = 285mm extension	
	TPR35-0570 = 570mm extension	
<b>Filling pipe / exhaust pipe extension</b>	TPR35-0855 = 855mm extension	+
	TPR35-1140 = 1140mm extension	
	+ = Excluded	
	SPR35-0285 = 285mm extension	
<b>Reduction kit (2" to 1")</b>	SPR35-0570 = 570mm extension	+
	SPR35-0855 = 855mm extension	
	SPR35-1140 = 1140mm extension	
	+ = Excluded	
<b>Packing</b>	4 = 4 off	+
	8 = 8 off	
<b>Packing</b>	T = for truck	T
	C = for container	

Outer / inner dia 3,588mm / 3,468mm  
Standards ENV 1991-1:1996 Eurocode 1-1 Calculations basis  
(among others) ENV 1991-2-1:1996 Eurocode 1-2 Actions on structure  
ENV 1991-2-3:1996 Eurocode 1-2-3 Snow loads  
ENV1991-2-4:1997 Eurocode 1-2-4 Wind actions  
ENV 1993-1-1-:1994A1:1998 Eurocode 3-1-1 Steel structures  
UNI EN 131/1 1994 Step ladders, stairways  
EN ISO 14122-3:2001 Stairways, stepladders, and guardrails  
Construction In carbon steel S235JR (EN134)  
Silo suitable for **Cement @ 1.4 density**  
Drawing of the silo Attached.  
Delivery 6-7 WEEKS DELIVERY



**STALLINGS HOUSE • STALLINGS LANE • KINGSWINFORD • WEST MIDLANDS • DY6 7LG**

**A TRADING DIVISION OF MIDLAND SPECIALIST ENGINEERING**

COMPANY REGISTRATION No. 5240743 VAT REGISTRATION No. 851 207 156



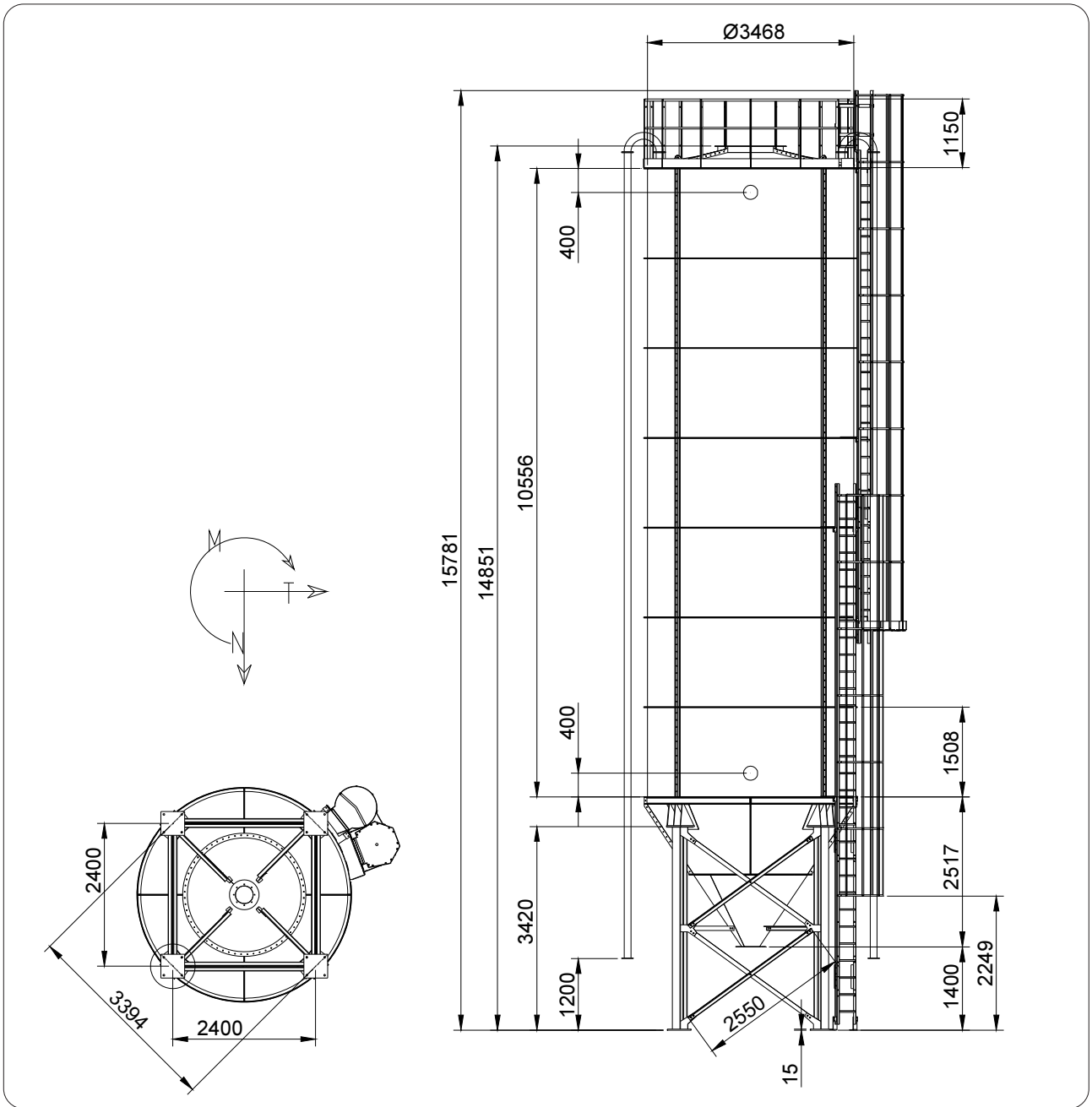

Max. stresses on individual columns - *Max. Belastung der einzelnen Säulen*  
 Contraintes maximales de chaque colonne - *Sollecitazioni massime singole colonne*

Code	Ferrules Siloschüsse Viroles - <i>Virole</i>	Capacity Fassungsvermögen Capacité - <i>Capacità</i>		Full silo - <i>Silo voll</i> Silo plein - <i>Silo pieno</i>			Empty silo in presence of wind <i>Leerer Silo bei Wind</i> Silo déchargé en présence de vent <i>Silo scarico in presenza di vento</i>		
		N°	m³ (*)	T (**)	N	T	M	N	T
<b>SPG35.110.04</b>	7	110	154	58719 kgf	1078 kgf	negligible <i>vernachlässigbar</i>	-5371 kgf	1037 kgf	negligible <i>vernachlässigbar</i>
<b>SPG35.110.02</b>				82767 kgf	3971 kgf	négligeable <i>trascurabile</i>	-5165 kgf	1037 kgf	négligeable <i>trascurabile</i>

**04** = Zona - Zona - Zona - Zona 4  
**02** = Zona - Zona - Zona - Zona 2

(\*) Silo internal volume - *Silovolumen* - Volume intérieur silo - Volume interno silo  
 (\*\*) Specific wt. of reference material (cement): 1.4 kg/dm³ - *Spezifisches Gewicht des Bezugsmaterials (Zement): 1,4 kg/dm³*  
 Poids spécifique matériau de référence (ciment): 1,4 kg/dm³ - Peso specifico materiale di riferimento (cemento): 1,4 kg/dm³